

VICINITY MAP

Scale 1" = 2000'

LEGAL DESCRIPTION

All that Part of the Southwest Quarter (SW $\frac{1}{4}$) of the Southwest Quarter (SW $\frac{1}{4}$) of the Northwest Quarter (NW $\frac{1}{4}$) of the Southwest Quarter (SW $\frac{1}{4}$), the Northeast Quarter (NE $\frac{1}{4}$) of the Southwest Quarter (SW $\frac{1}{4}$) and the Southeast Quarter (SE $\frac{1}{4}$) of the Southwest Quarter (SW $\frac{1}{4}$) all in Section 17, T-9-N, R-31-W, Van Buren, Crawford County, Arkansas lying South and West of Interstate Highway 40 and East of the St. Louis-San Francisco Railroad.

LESS AND EXCEPT that Part of the Southwest Quarter (SW $\frac{1}{4}$) of the Southwest Quarter (SW $\frac{1}{4}$) and Northwest Quarter (NW $\frac{1}{4}$) of the Southwest Quarter (SW $\frac{1}{4}$) of Section 17, T-9-N, R-31-W, described as follows:

Beginning at the SW corner of said Section 17; thence S 86°09' E, 280.0 feet along the South line of said Section 17 to the SE corner of Lot 21 of Rolling Hills North (A Residential Subdivision) as filed March 19, 1975; thence N 13°51' E, 300.0 feet along the Easterly boundary of said Rolling Hills North; thence N 55°42' E, 715.9 feet along said Easterly boundary; thence N 58°37'23" E, 437.09 feet; thence N 08°07'23" E, 230.00 feet; thence N 62°12'37" W, 376.00 feet; thence N 27°47'23" E, 250.00 feet to the Southerly right-of-way of Interstate Highway 40; thence N 62°12'37" W, 580.00 feet along said Southerly right-of-way; thence S 84°41'57" W, 127.18 feet along said Easterly right-of-way; thence S 22°43' W, 140.0 feet along said right-of-way, said Point being on the Easterly right-of-way of the St. Louis-San Francisco Railroad; thence S 22°43' W, 1146.5 feet along said right-of-way to the West line of said Section 17; thence South, 793.5 feet along said West line to the Point of Beginning.

and a 50' x 50' strip at the end of Anna Sue Road between Lots 81 and 89, Rolling Hills. Also, a 50' x 50' strip at the end of Mable Nell Road between Lots 104 and 97, Rolling Hills.

Containing 52.9 Acres More or Less.

PLANNING COMMISSION APPROVAL

DATE _____
CHAIRMAN _____
SECRETARY _____

SUBDIVISION REVIEW APPROVAL

DATE _____
CHAIRMAN _____
SECRETARY _____

CITY COUNCIL APPROVAL

DATE _____
MAYOR: _____
ATTESTED BY _____
CITY CLERK _____

TYPICAL 27' ASPHALT PAVEMENT
N.T.S.

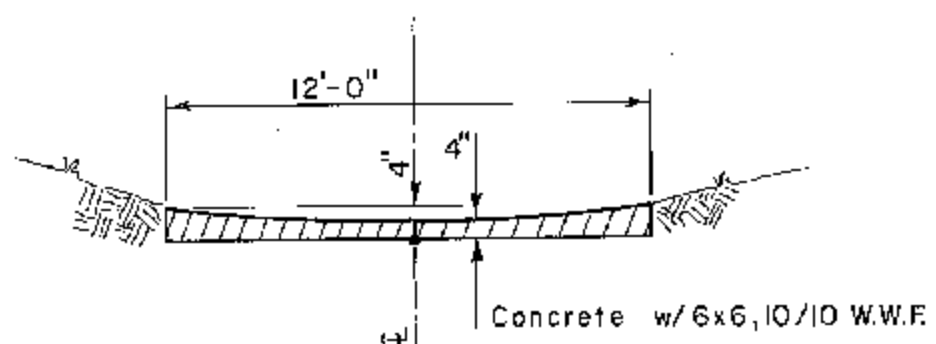

SECTION-12' REAR ACCESS DRIVE

Scale 1/4" = 1'-0"



UNPLATTED
TOBY BESSON
(OWNER)

REVISED JUNE 23, 1980
PER PLANNING COMMISSION MEETING OF JUNE 24, 1980
REVISED JUNE 17, 1980

BUTTERFIELD ADDITION

PHASE I - LOTS 1 THRU 12 & 19 THRU 28

PRELIMINARY LAYOUT
A PART OF THE SW 1/4 OF SECTION 17, T-9-N, R-31-W VAN BUREN, CRAWFORD COUNTY, ARKANSAS

APPROVED BY _____	DATE June 1980
DRAWN BY T.V.P.	JOB NO. 80-9
HORIZ. SCALE 1" = 100'	SHEET _____
VERT. SCALE _____	OF _____

Mickle-Wagner Assoc., Inc.
ENGINEERS, CONSULTANTS
FORT SMITH, ARKANSAS